



## Flame Detector

## QRA4.U

Flame detector for use with burner controls from Siemens Building Technologies for the supervision of gas or oil flames.

The QRA4.U and this Data Sheet are intended for use by OEMs which integrate the flame detectors in their products.

### Use

The flame detector is used for the supervision of gas flames, yellow- or blue-burning oil flames and for ignition spark proving.

Type reference	For use with burner controls type	Operating mode
QRA4.U	LGB2... / LGB4... with AGQ1... LFL... LFE1... LFE10... LMG... with AGQ2...	Intermittent

## Warning notes

---



**To avoid injury to persons, damage to property or the environment, the following warning notes should be observed!**

### **Do not open, interfere with or modify the flame detector!**

- Before performing any wiring changes in the connection area of the detector, completely isolate the equipment from the mains supply (all-polar disconnection)
- Ensure protection against electric shock hazard by providing adequate protection for the connection terminals
- Check to ensure that wiring is in an orderly state
- Halogen lamps, welding equipment, special lamps or ignition sparks may produce sufficient radiation for the detector's UV cell to ignite. X-rays and gamma radiation can also generate erroneous flame signals
- Fall or shock can adversely affect the safety functions. Such units may not be put into operation, even if they do not exhibit any damage

## Mounting notes

---

- Ensure that the relevant national safety regulations are complied with
- Mounting work must be carried out by qualified staff

## Installation notes

---

- Installation work must be carried out by qualified staff
- Always run the high-voltage ignition cables separate while observing the greatest possible distance to the detector and to other cables

## Electrical connection of the flame detector

---

It is important to achieve practically disturbance- and loss-free signal transmission:

- Never run the detector cable together with other cables
  - Line capacitance reduces the magnitude of the flame signal
  - Use a separate cable

## Commissioning notes

- Commissioning work must be carried out by qualified staff
- Prior to commissioning, ensure that wiring is in an orderly state
- Trouble-free burner operation is only ensured when the intensity of UV radiation at the detector's location is high enough for the detector's UV cell to ignite during each half wave.  
The **intensity of UV radiation** at the detector's location is **checked by measuring the detector current**

Measuring circuit  
for QRA4.U

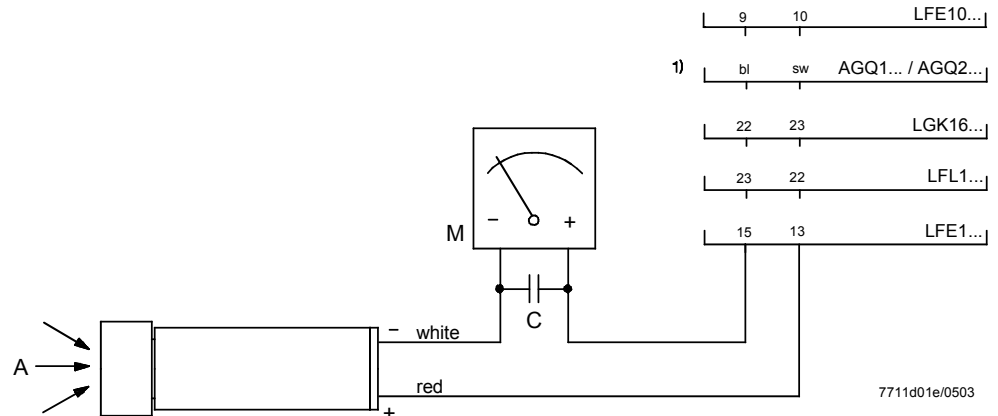

## Legend

- 1) Connection of microammeter across adapter AGQ1... / AGQ2... and flame detector  
 A Incidence of radiation  
 M Microammeter (DC), internal resistance  $\leq 5000 \Omega$   
 C Electrolytic capacitor 100...470  $\mu\text{F}$ , DC 10...25 V

## Certificates

**CE** Conformity to EEC directives  
 - Electromagnetic compatibility EMC (immunity) 89 / 336 EEC  
 - Directive for gas appliances 90 / 396 EEC  
 - Low-voltage directive 73 / 23 EEC



ISO 9001: 2000  
Cert. 00739



ISO 14001: 1996  
Cert. 38233



## Service notes

- Maintenance work must be carried out by qualified staff
- Each time a flame detector has been replaced, check to ensure that wiring is in an orderly state and make the safety check according to «Commissioning notes»

## Disposal notes



The flame detector contains electrical and electronic components and may not be disposed of together with household waste.  
Local and currently valid legislation must be observed.

## Mechanical design

---

Flame detector QRA4.U      Housing made of aluminium, with 3/4"-14NPSM connecting thread for fitting the detector to the burner or boiler.  
Connecting wires of about 1.8 m length for the electrical connection.  
1/2"-14NPSM thread for a fitting, required for the connection of a Mezel tube for protecting the connecting wires (1/2" conduit).

## Technical data

---

General detector data	Average life of UV cell	approx. 10'000 hours at max. +50 °C, higher ambient temperatures reduce considerably the cell's life
	Degree of protection	IP 54 (to be ensured through mounting)
	Mounting position	optional
	Weight	approx. 180 g
	Perm. combustion chamber pressure	max. 150 mbar
Environmental conditions	<b>Transport</b>	IEC 721-3-2
	Climatic conditions	class 2K3
	Mechanical conditions	class 2M2
	Temperature range	-20...+60 °C
	Humidity	< 95 % r.h.
	<b>Operation</b>	IEC 721-3-3
	Climatic conditions	class 3K5
	Mechanical conditions	class 3M5
	Temperature range	-20...+60 °C
	Humidity	< 95 % r.h.



**Condensation, formation of ice and ingress of water are not permitted!**

## Function

---

With this type of flame supervision, the UV radiation emitted by gas or oil flames is used to generate the flame signal.  
The radiation detector is a UV-sensitive cell with 2 electrodes, which ignite when illuminated with radiation in the 190...270 nm range of the spectrum, thereby triggering a current in the flame detector circuit.  
The UV cell does not respond to glowing firebrick in the combustion chamber or daylight.

## Dimensions

Dimensions in mm

Flame detector QRA4.U

